



Automation of the Illumina Nextera® XT System DNA Library Prep Workflow on PIPETMAX®

APPLICATION NOTE TRANS1116

The Illumina Nextera® XT System DNA Library Preparation Kit workflow was automated on PIPETMAX®. For comparison, 12 technical replicate libraries were prepared side by side, using manual liquid handling or automated on PIPETMAX®. The 24 libraries were pooled and sequenced on an Illumina MiSeq® sequencing system. Both library preparation methods generated high quality data with >95% mapped reads and optimal quality scores. Variance was lower for libraries generated with PIPETMAX®, consistent with the reproducible performance of this automated pipetting system. Automation of the Nextera® XT System workflow with PIPETMAX® allows libraries to be prepared in parallel and provides walk-away time, freeing up the researcher to carry out other tasks. More importantly, this application demonstrates the reliability and process control that is important for complex workflows, such as next generation sequencing.

INTRODUCTION

The Illumina Nextera® XT System DNA Library Preparation Kit¹ is designed to rapidly prepare sequencing-ready libraries of plasmids or small genomes for next generation sequencing, also referred to as massively parallel sequencing or deep sequencing.² In order to automate this workflow five automated scripts were developed for PIPETMAX®^{3,4} (Figure 1). These scripts, accessed via TRILUTION® micro software, automate the liquid handling steps of the tagmentation, amplification plate setup, library cleanup, library normalization, and library pooling procedures (Figure 2).

In this application note we compare sequencing-ready libraries that were generated using either manual liquid handling or the automated PIPETMAX® liquid handling instrument.

For each method (manual and PIPETMAX®) 12 replicate libraries were prepared from *E. coli* genomic DNA. The 24 libraries were pooled and then sequenced in one lane of an Illumina MiSeq® system.

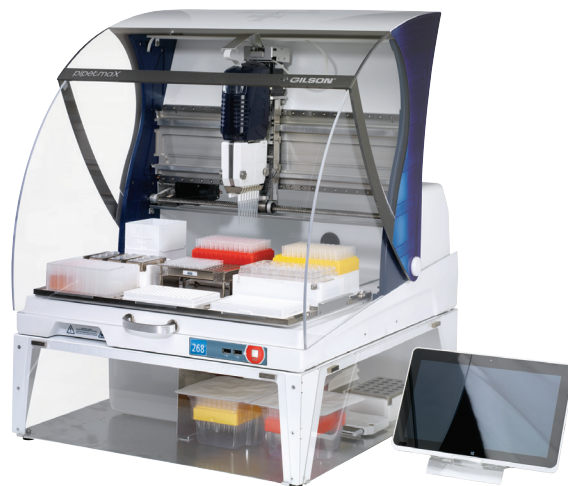

Figure 1: PIPETMAX® 268 is a benchtop, automated liquid handler equipped with motorized, multichannel, air displacement pipettes.



Figure 2: Schematic representation of the five PIPETMAX® scripts for automation of the Nextera® XT System DNA Library Kit workflow. Each blue rounded rectangle represents one PIPETMAX® script, each of which corresponds to a portion of the Nextera® XT System workflow. Some scripts include repositioning the plate or off-bed steps accomplished through user intervention, such as centrifugation of a microplate between liquid handling steps.



MATERIALS AND METHODS

Nucleic Acid Samples

E. coli K12 genomic DNA was obtained from a commercial source and diluted to the recommended concentration (0.2 ng/ μ L) before use. The same stock of genomic DNA was used for both manual and automated library preparation.

AUTOMATED LIQUID HANDLING

Automated liquid handling was performed with a Gilson PIPETMAX[®] 268 equipped with multichannel pipette heads (MAX8x20 and MAX8x200). (A list of Gilson-supplied items is on the last page.) The removable tray on PIPETMAX[®] can hold up to nine ANSI/SLAS-footprint items, including Gilson PIPETMAN[®] DIAMOND tips, microplates, microcentrifuge tubes or PCR tubes in racks, reservoirs, tip waste, and accessories such as the magnetic bead separator or orbital shaker. Gilson PIPETMAN[®] DIAMOND tips in tip adapter blocks were used for all automated liquid handling.

Gilson TRILUTION[®] micro software running on a tablet PC was used to control PIPETMAX[®] and on-bed accessories including the magnetic bead separator and orbital shaker. To obtain the PIPETMAX[®] scripts for automated Illumina Nextera[®] XT System DNA Library Preparation discussed in this application note, please contact techsupport@gilson.com.

Library Preparation, Sequencing, and Bioinformatics

Library preparation and sequencing was performed by an Illumina Certified Service Provider (Lucigen Corp., Madison, WI). Twelve libraries were constructed using manual liquid handling, with *E. coli* gDNA (1 ng) as input material and i5 and i7 index primers, following manufacturer's guidelines (Illumina Nextera[®] XT System reagents p/n FC-131-1096 and FC-131-1001). Twelve additional libraries were created on PIPETMAX[®], using the same source

and concentration of *E. coli* gDNA and a different combination of i5 and i7 index primers. Following library cleanup with Agencourt[®] AMPure[®] XP beads (Beckman Coulter p/n A63880), libraries were checked for size distribution and sample purity via an Agilent Bioanalyzer. All 24 libraries were then pooled and run on an Illumina MiSeq[®] sequencing system. Sequencing reads were downsampled to 312,400 reads per library and mapped to the *E. coli* K12 genome.

Equipment and Labware

A list of Gilson-supplied items can be found on the last page. Additionally, the following labware was used in the automated procedures:

Table 1: Labware used in automated scripts.

Description	Part Number	Notes
Labware for Tagmentation & Amplification	Eppendorf twin. tec 0030133307	96-well, unskirted microplate
Reaction plate	Bio-Rad HSP-9601	96-well, hard shell, skirted microplate
Sample plate	Greiner 659101	96-well, clear, V-bottom polystyrene, low binding microplate
Reservoir	Agilent Seahorse 201256-100	12 column reservoir
Strip tubes	Thermo AB-0451	0.2 mL strip tubes
Midi plate	Thermo AB-0859	96-well, deep well plate used for library normalization script
RoboRack	Micronic MPW51001BC3	Rack to hold Illumina TruSeq Index primers for Amplification plate setup script
2 mL tube	Greiner 623201	2 mL flip cap microcentrifuge tube



RESULTS AND DISCUSSION

Sequencing-ready normalized libraries were generated with the Nextera® XT System DNA Library Preparation Kit from an input of 1 ng per library using manual liquid handling or PIPETMAX® liquid handling. A Gilson PIPETMAX® equipped with two motorized multichannel air displacement pipette heads was used to carry out automated liquid handling for the tagmentation of *E. coli* genomic DNA, as well as PCR amplification reaction setup, bead cleanup, library normalization, and library pooling. The system enables precise single or multichannel pipetting from 1 µL to 200 µL and was outfitted with on-bed accessories for orbital shaking, magnetic

bead cleanup, and dispensing of index primers into the proper positions. The efficient layout of the compact benchtop instrument permits up to nine bed elements to be employed during an automated script.

The intuitive TRILUTION® micro software provides a “wizard”-style interface to guide the user through instrument and script setup. The ease of use of the software decreases user-to-user variability and the built-in help information reduces training needs. The TRILUTION® micro graphical interface walks users through run setup. Scripts include prompts when off-bed steps are required. Detailed run reports (Figure 3) help with sample tracking.

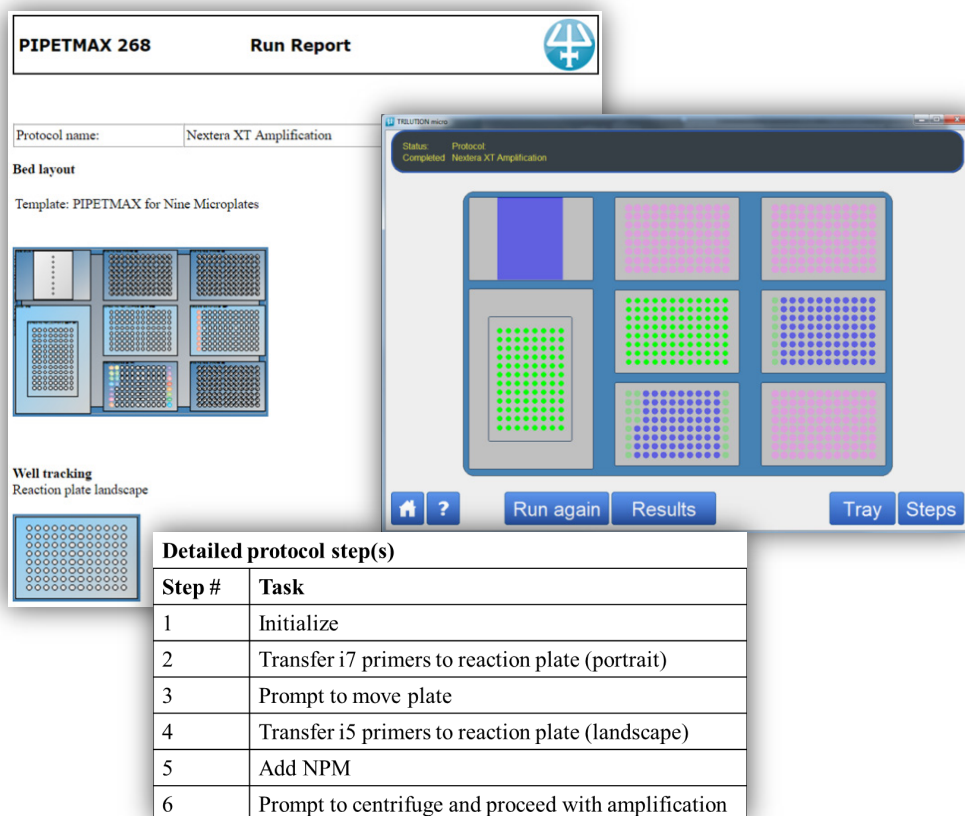

Figure 3: Example images from PIPETMAX® run report, TRILUTION® micro graphical interface, and list of script steps. Example shown: Nextera XT amplification plate setup.

PIPETMAX® Accessories

Some of the PIPETMAX® accessories that were employed in the Amplification, Cleanup and Normalization scripts are of note because they helped to increase efficiency in the workflow. These are shown in Figure 4.

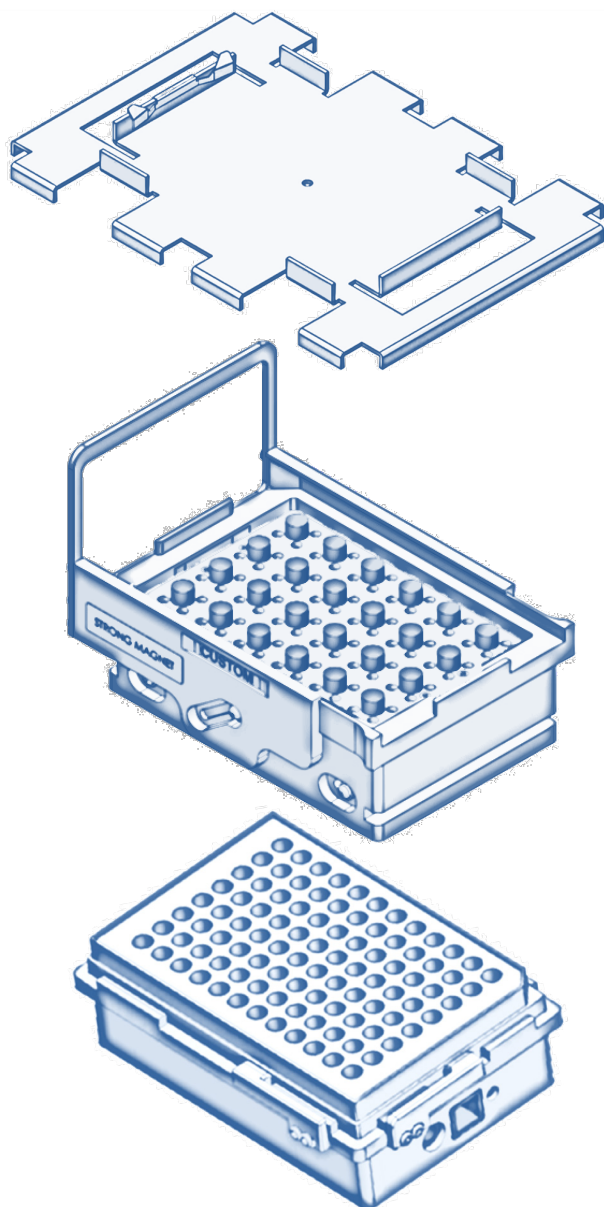

Figure 4: Some of the PIPETMAX® Accessories used in this workflow. From top to bottom: portrait orientation rack, magnetic bead separator, and orbital shaker.

1) The Portrait Orientation Rack (SPL-2141C-HDW) is used in the Amplification script. This rack allows the user to manually rotate the reaction plate 90°, which enables multichannel addition of the index primers. 2) A Micronic Roborack-96 was employed as an on-bed rack for index primer tubes in the Amplification script. The primers are held in this automation-friendly rack that fits the TruSeq® Index Primer tubes. PIPETMAX® can access the primer tubes and transfers primers to the correct position in the reaction plate. 3) The Gilson magnetic bead separator is used in both the Library Cleanup and Library Normalization scripts. The magnets in this on-bed device can be automatically toggled between disengaged and engaged positions, facilitating washing and elution steps. 4) The Orbital Shaker for PIPETMAX® is used in the Library Normalization script. The user manually places the labware on the shaker, and PIPETMAX® regulates the speed and time of shaking according to the needs of the application as designated in the script.

Sequencing Results

For each method (manual and PIPETMAX®) twelve replicate libraries were prepared from *E. coli* genomic DNA. The 24 libraries were then pooled and sequenced on an Illumina MiSeq™ system. Sequencing results demonstrated the reliability of the automated Nextera® XT System Library Preparation script.

The percentage of mapped reads was almost identical for libraries prepared with automated liquid handling or manual liquid handling. In general, the libraries prepared with PIPETMAX® exhibited smaller standard deviation and variance, consistent with the reproducibility of liquid handling on this system. Each library was downsampled to 312,500 reads, which yielded >8x coverage for all 24 libraries.

Libraries constructed with either PIPETMAX® or manual liquid handling performed well, achieving >95% mapped reads and >8x coverage of the genome (see Table 2).



The variance observed for libraries constructed with the PIPETMAX® automated workflow were slightly smaller than those prepared manually (30.8% vs. 34.1%), indicating the technical replicates prepared with PIPETMAX® were more uniform than the technical replicates prepared with manual pipetting.

Table 2: Comparison of sequencing results for libraries prepared using PIPETMAX® or manual liquid handling.

		<i>Avg</i>	<i>StDev</i>	<i>Variance</i>
PIPETMAX®	Total reads	736,016	226,252	30.8%
	% Mapped	95.7%	1.2%	
	Fold coverage	8.311x	0.135	1.6%
	% reads >Q30	93.5%	2.2%	4.3%
Manual	Total reads	853,963	291,140	34.1%
	% Mapped	95.1%	1.5%	
	Fold coverage	9.395x	0.174	1.9%
	% reads >Q30	90.3%	3.2%	9.3%

Figure 5 compares the percentage of mapped reads and the quality scores (% >Q30) averaged across twelve replicate libraries prepared either with PIPETMAX® or manual pipetting. Automation of Nextera® XT System DNA preparation with PIPETMAX® provided reproducible liquid handling, resulting in smaller standard deviations and lower variance between replicates.

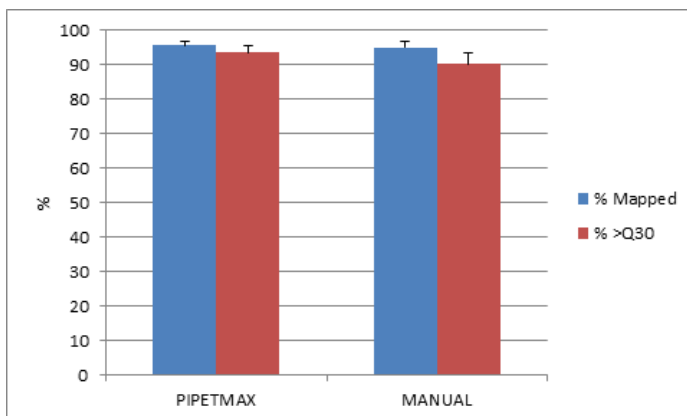

Figure 5: Comparison of % mapped reads (blue columns) and % >Q30 (red columns) values.

REFERENCES

1. Illumina. (2016) Nextera® DNA Library Prep Reference Guide. Document # 15027987 v01. Accessed April 2016. Available from http://support.illumina.com/content/dam/illumina-support/documents/documentation/chemistry_documentation/samplepreps_nextera/nexteradna/nextera-dna-library-prep-reference-guide-15027987-01.pdf
2. Jerzy K. Kulski. (2016). Next-Generation Sequencing — An Overview of the History, Tools, and “Omic” Applications, Next Generation Sequencing. In: Advances, Applications and Challenges, Dr. Jerzy Kulski (Ed.), InTech, DOI: 10.5772/61964. Accessed August 2016. Available from: <http://www.intechopen.com/books/next-generation-sequencing-advances-applications-and-challenges/next-generation-sequencing-an-overview-of-the-history-tools-and-omic-applications>
3. Guckenberger DJ, Thomas PC, Rothbauer J, LaVanway AJ, Anderson M, Gilson D, Fawcett K, Berto T, Barrett K, Beebe DJ, Berry SM. A Combined Fabrication and Instrumentation Platform for Sample Preparation. J Lab Autom. 2014 Jun;19(3):267-74. doi: 10.1177/2211068213518312. Epub 2014 Jan 8. Accessed August 2016. Available from <http://jla.sagepub.com/content/19/3/267.long>
4. Gilson. PIPETMAX® 268 User’s Guide. Document LT255519-06. Accessed August 2016. Available from: [http://www.gilson.com/Resources/PIPETMAX®_268_Users_Guide_LT255519_06.pdf](http://www.gilson.com/Resources/PIPETMAX_268_Users_Guide_LT255519_06.pdf)
5. Illumina. Quality Scores for Next-Generation Sequencing. Technical Note. Pub. No. 770-2011-030. Accessed August 2016. http://www.illumina.com/documents/products/technotes/technote_Q-Scores.pdf



ACKNOWLEDGMENTS

This work was carried out by Laura Simdon and Seth Hanson of Gilson, Inc. in collaboration with Brandon Converse, Brendan Keough and Scott Monsma of Lucigen, Corporation. Lucigen is an Illumina certified sequencing provider.

CONCLUSIONS

- The Nextera® XT System DNA Library Preparation Kit workflow was automated as five PIPETMAX® scripts, each of which corresponds to a portion of the Nextera® XT System workflow.
- Libraries generated using the PIPETMAX® automated Nextera® XT System DNA Library Kit scripts are ready for downstream Illumina sequencing.
- Automation of the Nextera® XT System workflow with PIPETMAX® allows libraries to be generated in parallel, reduces the need for hands-on time, and offers reproducible liquid handling, thereby enabling verifiable science.
- Custom accessories were implemented to enable fast, optimal multichannel pipetting as well as manipulation of magnetic beads:
 - 90° adapter rack
 - Orbital shaker
 - Magnetic bead separator

TRADEMARKS

All product names, brands, and logos are the property of their respective owners. All company, product and service names used in this document are for identification purposes only. Use of these names, brands, and logos does not imply endorsement.

ORDERING INFORMATION

<i>Part Number</i>	<i>Description</i>
32100001	PIPETMAX® 268 with Cover Cutouts
FC10021	MAX8x200 Pipette Head
FC10022	MAX8x20 Pipette Head
32000091	PIPETMAX® 268 Tray 384 Well
32000175	PIPETMAX® Tip Adapter Blocks (qty 3)
32000321	TRILUTION micro installed on touchscreen tablet
32000177	Tip Storage Riser for PIPETMAX®
SPL-2294F-HDW	Magnetic Bead Separator
SPL-2294E-HDW	Magnet Plate
40000026	Thumbscrew (qty 6)
32000292	Reload Block Clip (qty 4)
4214540393	Washer (qty 4)
32000199	Orbital Shaker for PIPETMAX®
32000247	PIPETMAX® 268 On-Bed Device Cable Guide
21014736-CSP	Converter, USB to Serial Single Port
32000198	Rack Code 424 1.5–2.0 mL Tube Flip Cap
SPL-2141C-HDW	Portrait Adapter Rack
32000303	Microamp Short 96 PCR Tube Rack (qty 2)
F172513	DSF200ST PIPETMAN® DIAMOND Tips in Blister Pack
F172313	DSF30ST PIPETMAN® DIAMOND tips in Blister Pack